

DIN EN 1563



ICS 77.080.10

Supersedes
DIN EN 1563:2005-10

**Founding –
Spheroidal graphite cast irons
English translation of DIN EN 1563:2012-03**

Gießereiwesen –
Gusseisen mit Kugelgraphit
Englische Übersetzung von DIN EN 1563:2012-03

Fonderie –
Fontes à graphite sphéroïdal
Traduction anglaise de DIN EN 1563:2012-03

Document comprises 50 pages

Translation by DIN-Sprachendienst.

In case of doubt, the German-language original shall be considered authoritative.



A comma is used as the decimal marker.

National foreword

This standard has been prepared by Technical Committee CEN/TC 190 “Foundry technology” (Secretariat: DIN, Germany).

The responsible German body involved in its preparation was the *Normenausschuss Gießereiwesen* (Foundry Practice Standards Committee), Working Committee NA 036-00-01 AA *Gusseisenwerkstoffe*.

Amendments

This standard differs from DIN EN 1563:2005-10 as follows:

- a) further solid-solution strengthened ferritic spheroidal graphite cast iron grades have been added (see Introduction for more information);
- b) Clause 3 “Terms and definitions” has been extended to include:
 - ferritic to pearlitic spheroidal graphite cast iron (3.2);
 - solid-solution strengthened ferritic spheroidal graphite cast iron (3.3);
 - cast sample (3.5);
 - separately cast sample (3.6);
 - side-by-side cast sample (3.7);
 - cast-on sample (3.8);
 - relevant wall thickness (3.9).
- c) mechanical properties are now given as a function of the relevant wall thickness in Tables 1, 2 and 3, and the classification as a function of hardness (given in Annex A of EN 1563:1997) has been withdrawn:
 - Tables 1 and 2 concerning ferritic to pearlitic spheroidal graphite cast irons have been restructured, the required minimum impact energy values apply to several types of cast samples and are now given for three ranges of relevant wall thicknesses;
 - in Table 3 relating to solid-solution strengthened ferritic spheroidal graphite cast irons, the required minimum mechanical properties apply to several types of cast samples and are now given for three ranges of relevant wall thicknesses;
 - in Table 4, types and sizes of cast samples and sizes of tensile test pieces are now given in relation to the relevant wall thickness of the casting.
- d) Annexes:
 - Annex A is now informative and gives additional information on solid-solution strengthened ferritic spheroidal graphite cast irons;
 - Annex B (informative) replaces the former Annex D of EN 1563:1997 and gives guidance values for mechanical properties measured on test pieces machined from samples cut from the castings, for three ranges of relevant wall thicknesses;
 - Annex C (informative) now gives guidance values for hardness;
 - Annex D (informative) now gives information relating to nodularity;
 - Annex E (informative) replaces the former Annex B of EN 1563:1997 and gives additional information on mechanical and physical properties of solid-solution strengthened ferritic spheroidal graphite cast irons.

The former normative Annex E of EN 1563:1997 “Formation of test units and number of tests” has been dropped;

The following new annexes have been included:

- Annex F (informative) “Fracture toughness, impact energy and ductility of spheroidal graphite cast irons”;
- Annex G (normative) “Sectioning procedure for cast samples”;
- Annex H (informative) “Comparison of spheroidal graphite cast iron material designations according to EN 1560 [1] and ISO/TR 15931 [24]”;
- Annex I (informative) “Un-notched impact test”;

e) the Bibliography (which is no longer an annex) has been transferred to the end of the standard.

Previous editions

DIN 1693: 1961-09

DIN 1693-1: 1973-10

DIN 1693-2: 1977-10

DIN EN 1563: 1997-08, 2002-08, 2003-02, 2005-10

— This page is intentionally blank —

English Version

Founding - Spheroidal graphite cast irons

Fonderie - Fontes à graphite sphéroïdal

Gießereiwesen - Gusseisen mit Kugelgraphit

This European Standard was approved by CEN on 12 November 2011.

CEN members are bound to comply with the CEN/CENELEC Internal Regulations which stipulate the conditions for giving this European Standard the status of a national standard without any alteration. Up-to-date lists and bibliographical references concerning such national standards may be obtained on application to the CEN-CENELEC Management Centre or to any CEN member.

This European Standard exists in three official versions (English, French, German). A version in any other language made by translation under the responsibility of a CEN member into its own language and notified to the CEN-CENELEC Management Centre has the same status as the official versions.

CEN members are the national standards bodies of Austria, Belgium, Bulgaria, Croatia, Cyprus, Czech Republic, Denmark, Estonia, Finland, France, Germany, Greece, Hungary, Iceland, Ireland, Italy, Latvia, Lithuania, Luxembourg, Malta, Netherlands, Norway, Poland, Portugal, Romania, Slovakia, Slovenia, Spain, Sweden, Switzerland and United Kingdom.



EUROPEAN COMMITTEE FOR STANDARDIZATION
COMITÉ EUROPÉEN DE NORMALISATION
EUROPÄISCHES KOMITEE FÜR NORMUNG

Management Centre: Avenue Marnix 17, B-1000 Brussels

Contents

	Page
Foreword.....	3
Introduction	4
1 Scope	5
2 Normative references	5
3 Terms and definitions	5
4 Designation	6
5 Order information	7
6 Manufacture.....	7
7 Requirements	7
7.1 General.....	7
7.2 Ferritic to pearlitic spheroidal graphite cast irons.....	8
7.3 Solid solution strengthened ferritic spheroidal graphite cast irons	11
8 Sampling.....	12
8.1 General.....	12
8.2 Cast samples.....	13
8.3 Samples cut from a casting	14
9 Test methods.....	19
9.1 Tensile test	19
9.2 Impact test	20
9.3 Hardness test	21
9.4 Graphite structure examination	21
10 Retests	21
10.1 Need for retests.....	21
10.2 Test validity	22
10.3 Non-conforming test results.....	22
10.4 Heat treatment of samples and castings.....	22
11 Inspection documentation	22
Annex A (informative) Additional information on solid solution strengthened ferritic spheroidal graphite cast irons.....	23
Annex B (informative) Guidance values for mechanical properties measured on test pieces machined from samples cut from the castings	27
Annex C (informative) Guidance values for hardness.....	29
Annex D (informative) Nodularity	31
Annex E (informative) Additional information on mechanical and physical properties	32
Annex F (informative) Fracture toughness, impact energy and ductility of spheroidal graphite cast irons	34
Annex G (normative) Sectioning procedure for cast samples	38
Annex H (informative) Comparison of spheroidal graphite cast iron material designations according to EN 1560 [1] and ISO/TR 15931 [24].....	39
Annex I (informative) Un-notched impact test.....	40
Annex J (informative) Significant technical changes between this European Standard and the previous edition	42
Annex ZA (informative) Relationship between this European Standard and the Essential Requirements of EC Directive 97/23/EC	44
Bibliography	45

Foreword

This document (EN 1563:2011) has been prepared by Technical Committee CEN/TC 190 “Foundry technology”, the secretariat of which is held by DIN.

This European Standard shall be given the status of a national standard, either by publication of an identical text or by endorsement, at the latest by June 2012, and conflicting national standards shall be withdrawn at the latest by June 2012.

Attention is drawn to the possibility that some of the elements of this document may be the subject of patent rights. CEN [and/or CENELEC] shall not be held responsible for identifying any or all such patent rights.

This document supersedes EN 1563:1997.

This document has been prepared under a mandate given to CEN by the European Commission and the European Free Trade Association, and supports essential requirements of EU Directive(s).

For relationship with EU Directive 97/23/EC, see informative Annex ZA, which is an integral part of this document.

Within its programme of work, Technical Committee CEN/TC 190 requested CEN/TC 190/WG 7 “Spheroidal graphite, silicon molybdenum and austempered ductile iron” to revise EN 1563:1997.

Annex J provides details of significant technical changes between this European Standard and the previous edition.

According to the CEN/CENELEC Internal Regulations, the national standards organizations of the following countries are bound to implement this European Standard: Austria, Belgium, Bulgaria, Croatia, Cyprus, Czech Republic, Denmark, Estonia, Finland, France, Germany, Greece, Hungary, Iceland, Ireland, Italy, Latvia, Lithuania, Luxembourg, Malta, Netherlands, Norway, Poland, Portugal, Romania, Slovakia, Slovenia, Spain, Sweden, Switzerland and the United Kingdom.

Introduction

The properties of spheroidal graphite cast irons depend on their structure.

Spheroidal graphite cast irons covered by this European Standard are divided in two groups:

- 1) ferritic to pearlitic spheroidal graphite cast irons which were in the previous standard;
- 2) solid-solution strengthened ferritic spheroidal graphite cast irons which were not in the previous standard.

The two groups present specific properties, for example:

- the ferritic grades of the first group present the highest impact energy;
- the pearlite containing grades are more suitable for wear resistance applications;
- the solid-solution strengthened ferritic grades present for an equivalent tensile strength a higher proof strength and a higher elongation than that of the ferritic to pearlitic grades;
- a significant property of these solid-solution strengthened ferritic grades is the reduced hardness variation resulting in an improved machinability.

The mechanical properties of the material can be evaluated on machined test pieces prepared from:

- separately cast samples;
- side-by-side cast samples;
- cast-on samples;
- samples cut from a casting.

The material grade is defined by mechanical properties measured on machined test pieces prepared from cast samples.

If hardness or un-notched impact energy are a requirement of the purchaser as being important for the application, then Annex C or Annex I provide means for its determination.

It is well known that tensile properties and hardness of spheroidal graphite cast irons are interrelated. When considered by the purchaser as being important for the application, both tensile and hardness properties may be specified.

Further technical data on spheroidal graphite cast irons is given in Annexes A, E and F.

In this European Standard a new designation system by number, as established in EN 1560:2011 [1], is given.

NOTE This designation system by number is based on the structure and rules of EN 10027-2 [2] and so corresponds with the European numbering system for steel and other materials.

Some spheroidal graphite cast iron grades can be used for pressure equipment.

The permitted material grades of spheroidal graphite cast iron for pressure applications and the conditions for their use are given in specific product or application standards.

For the design of pressure equipment, specific design rules apply.

Annex ZA gives information relating to the conformance of permitted spheroidal graphite cast iron grades to the Pressure Equipment Directive 97/23/EC.

1 Scope

This European Standard defines the grades and the corresponding requirements for spheroidal graphite cast irons.

This European Standard specifies 2 groups of spheroidal graphite cast iron grades by a classification based on mechanical properties measured on machined test pieces prepared from cast samples. The first group deals with ferritic to pearlitic grades. The second group deals with solid-solution strengthened ferritic grades.

This European Standard does not cover technical delivery conditions for iron castings (see EN 1559-1 [3] and EN 1559-3 [4]).

This European Standard does not cover all aspects of:

- ausferritic spheroidal graphite cast irons which are specified in EN 1564 [5];
- low alloyed ferritic spheroidal graphite cast irons which are specified in EN 16124 [6];
- austenitic cast irons which are specified in EN 13835 [7];
- spheroidal graphite cast irons used for pipes, fittings and their joints which are the subject of EN 545 [8], EN 598 [9] and EN 969 [10];
- the grades of spheroidal graphite cast iron as specified in EN 545 which are used for products such as industrial valves, non industrial manually operated shut-off valves and flanges and their joints, which are the subject of the applicable European product standards.

2 Normative references

The following referenced documents are indispensable for the application of this document. For dated references, only the edition cited applies. For undated references, the latest edition of the referenced document (including any amendments) applies.

EN 764-5:2002, *Pressure Equipment — Part 5: Compliance and Inspection — Documentation of Materials*

EN 10204:2004, *Metallic products — Types of inspection documents*

EN ISO 148-1:2010, *Metallic materials — Charpy impact test — Part 1: Test method (ISO 148-1:2009)*

EN ISO 945-1:2008, *Microstructure of cast irons — Part 1: Graphite classification by visual analysis (ISO 945-1:2008)*

EN ISO 6506-1, *Metallic materials — Brinell hardness test — Part 1: Test method (ISO 6506-1)*

EN ISO 6892-1:2009, *Metallic materials — Tensile testing — Part 1: Method of test at ambient temperature (ISO 6892-1:2009)*

3 Terms and definitions

For the purposes of this document, the following terms and definitions apply.

3.1

spheroidal graphite cast iron

cast material, iron, carbon and silicon-based, the carbon being present mainly in the form of spheroidal graphite particles

NOTE Spheroidal graphite cast iron is also known as ductile iron, and less commonly as nodular iron.

3.2

ferritic to pearlitic spheroidal graphite cast iron

spheroidal graphite cast iron with a matrix containing ferrite or pearlite or a combination of both

NOTE Pearlite can be partially or totally replaced by bainite or tempered martensite in grades having higher strength

3.3

solid-solution strengthened ferritic spheroidal graphite cast iron

spheroidal graphite cast iron with a matrix mainly consisting of ferrite, solution strengthened mainly by silicon

3.4

graphite spheroidizing treatment

operation that brings the liquid iron into contact with a substance to produce graphite in the predominantly spheroidal (nodular) form during solidification

NOTE This operation is often followed by a second one called inoculation.

3.5

cast sample

quantity of material cast to represent the cast material, including separately cast sample, side by side cast sample and cast-on sample

3.6

separately cast sample

sample cast in a separate sand mould under representative manufacturing conditions and material grade

3.7

side-by-side cast sample

sample cast in the mould alongside the casting, with a joint running system

3.8

cast-on sample

sample attached directly to the casting

3.9

relevant wall thickness

wall thickness representative of the casting, defined for the determination of the size of the cast samples to which the mechanical properties apply

4 Designation

The material shall be designated either by symbol or by number as given in Tables 1, 2 or 3.

In the case of samples cut from the casting the letter C is added at the end of the designation by symbol.

NOTE The comparison of EN 1563 grade designations with the grades from the ISO standard for spheroidal graphite cast iron, ISO 1083:2004 [11], is given in Annex H.

5 Order information

The following information shall be supplied by the purchaser:

- a) the number of this European Standard;
- b) the designation of the material;
- c) the relevant wall thickness;
- d) any special requirements.

All requirements shall be agreed between the manufacturer and the purchaser by the time of acceptance of the order (e.g. technical delivery conditions according to EN 1559-1 and EN 1559-3).

6 Manufacture

The method of producing spheroidal graphite cast irons and their chemical composition shall be left to the discretion of the manufacturer who shall ensure that the requirements of this European Standard are met for the material grade specified in the order.

— ferritic to pearlitic spheroidal graphite cast irons.

For these grades, the level of the mechanical properties is determined by the ferrite to pearlite ratio. This ratio is normally adjusted by alloying with pearlite stabilising elements or, less commonly, by heat treatment.

— solid-solution strengthened ferritic spheroidal graphite cast irons.

For these grades, the level of the mechanical properties is determined by the extent of solid solution strengthening of the ferritic matrix. This extent is normally governed by the silicon content.

NOTE For spheroidal graphite cast irons to be used in special applications, the chemical composition and heat treatment may be the subject of an agreement between the manufacturer and the purchaser.

All agreements between the manufacturer and the purchaser shall be made by the time of the acceptance of the order.

7 Requirements

7.1 General

The property values apply to spheroidal graphite cast irons cast in sand moulds or moulds of comparable thermal behaviour. Subject to amendments to be agreed upon in the order, they can apply to castings obtained by alternative methods.

The material designation is based on the minimum mechanical properties obtained in cast samples with a thickness or diameter of 25 mm. The designation is irrespective of the type of cast sample.

Mechanical properties are wall thickness dependant as shown in Tables 1, 2 and 3. For relevant wall thicknesses more than 200 mm, the manufacturer and the purchaser shall agree on the minimum values to be obtained and the type and size of the cast sample.

NOTE Tensile testing requires sound test pieces in order to guarantee pure uni-axial stress during the test.

7.2 Ferritic to pearlitic spheroidal graphite cast irons

7.2.1 Test pieces machined from cast samples

7.2.1.1 Tensile properties

The mechanical properties of ferritic to pearlitic spheroidal graphite cast iron test pieces shall be as specified in Table 1.

Table 1 — Mechanical properties measured on test pieces machined from cast samples for ferritic to pearlitic grades

Material designation		Relevant wall thickness	0,2 % proof strength	Tensile strength	Elongation
Symbol	Number	t mm	$R_{p0,2}$ MPa min	R_m MPa min	A % min
EN-GJS-350-22-LT ^a	5.3100	$t \leq 30$	220	350	22
		$30 < t \leq 60$	210	330	18
		$60 < t \leq 200$	200	320	15
EN-GJS-350-22-RT ^b	5.3101	$t \leq 30$	220	350	22
		$30 < t \leq 60$	220	330	18
		$60 < t \leq 200$	210	320	15
EN-GJS-350-22	5.3102	$t \leq 30$	220	350	22
		$30 < t \leq 60$	220	330	18
		$60 < t \leq 200$	210	320	15
EN-GJS-400-18-LT ^a	5.3103	$t \leq 30$	240	400	18
		$30 < t \leq 60$	230	380	15
		$60 < t \leq 200$	220	360	12
EN-GJS-400-18-RT ^b	5.3104	$t \leq 30$	250	400	18
		$30 < t \leq 60$	250	390	15
		$60 < t \leq 200$	240	370	12
EN-GJS-400-18	5.3105	$t \leq 30$	250	400	18
		$30 < t \leq 60$	250	390	15
		$60 < t \leq 200$	240	370	12
EN-GJS-400-15	5.3106	$t \leq 30$	250	400	15
		$30 < t \leq 60$	250	390	14
		$60 < t \leq 200$	240	370	11
EN-GJS-450-10	5.3107	$t \leq 30$	310	450	10
		$30 < t \leq 60$	to be agreed upon between the manufacturer and the purchaser		
		$60 < t \leq 200$	to be agreed upon between the manufacturer and the purchaser		
EN-GJS-500-7	5.3200	$t \leq 30$	320	500	7
		$30 < t \leq 60$	300	450	7
		$60 < t \leq 200$	290	420	5
EN-GJS-600-3	5.3201	$t \leq 30$	370	600	3
		$30 < t \leq 60$	360	600	2
		$60 < t \leq 200$	340	550	1
EN-GJS-700-2	5.3300	$t \leq 30$	420	700	2
		$30 < t \leq 60$	400	700	2
		$60 < t \leq 200$	380	650	1
EN-GJS-800-2	5.3301	$t \leq 30$	480	800	2
		$30 < t \leq 60$	to be agreed upon between the manufacturer and the purchaser		
		$60 < t \leq 200$	to be agreed upon between the manufacturer and the purchaser		
EN-GJS-900-2	5.3302	$t \leq 30$	600	900	2
		$30 < t \leq 60$	to be agreed upon between the manufacturer and the purchaser		
		$60 < t \leq 200$	to be agreed upon between the manufacturer and the purchaser		

NOTE The mechanical properties of test pieces machined from cast samples may not reflect exactly the properties of the casting itself. Values for tensile properties of the casting are given in Annex B for guidance.

^a LT for low temperature.
^b RT for room temperature.

7.2.1.2 Impact energy

The impact energy values given in Table 2 for room temperature (RT) and low temperature (LT) applications, if applicable, shall only be determined if specified by the purchaser by the time of acceptance of the order.

NOTE The use of impact energy is currently being reassessed regarding its limited relevance as a measure of resistance to brittle fracture in castings subject to application loads. Annex F gives information about fracture toughness, impact energy and ductility.

Table 2 — Minimum impact energy values measured on V-notched test pieces machined from cast samples for ferritic grades of the ferritic to pearlitic group

Material designation		Relevant wall thickness <i>t</i> mm	Minimum impact energy values					
			Room temperature (23 ± 5) °C		Low temperature (– 20 ± 2) °C		Low temperature (– 40 ± 2) °C	
			Mean value (3 tests)	Individual value	Mean value (3 tests)	Individual value	Mean value (3 tests)	Individual value
Symbol	Number							
EN-GJS-350-22-LT	5.3100	$t \leq 30$	—	—	—	—	12	9
		$30 < t \leq 60$	—	—	—	—	12	9
		$60 < t \leq 200$	—	—	—	—	10	7
EN-GJS-350-22-RT	5.3101	$t \leq 30$	17	14	—	—	—	—
		$30 < t \leq 60$	17	14	—	—	—	—
		$60 < t \leq 200$	15	12	—	—	—	—
EN-GJS-400-18-LT	5.3103	$t \leq 30$	—	—	12	9	—	—
		$30 < t \leq 60$	—	—	12	9	—	—
		$60 < t \leq 200$	—	—	10	7	—	—
EN-GJS-400-18-RT	5.3104	$t \leq 30$	14	11	—	—	—	—
		$30 < t \leq 60$	14	11	—	—	—	—
		$60 < t \leq 200$	12	9	—	—	—	—

NOTE The mechanical properties of test pieces machined from cast samples may not reflect exactly the properties of the casting itself.

7.2.2 Test pieces machined from samples cut from a casting

If applicable, the manufacturer and the purchaser shall agree on:

- the location(s) on a casting where the sample(s) shall be taken;
- the mechanical properties that shall be measured;
- the minimum values, or allowable range of values, for these mechanical properties (for information, see Annex B).

NOTE 1 The properties of castings may not be uniform, depending on the complexity of the castings and variation in their section thickness.

NOTE 2 Mechanical properties for test pieces cut from a casting are affected not only by material properties (subject of this European Standard) but also by the local casting soundness (not subject of this standard).

7.2.3 Hardness

Brinell hardness and its range values for the grades listed in Table 1 and 3 shall only be specified when agreed between the manufacturer and the purchaser by the time of acceptance of the order.

Information regarding hardness is given in Annex C.

7.2.4 Graphite structure

The graphite structure shall be mainly of form V and VI in accordance with EN ISO 945-1. A more precise definition may be agreed upon by the time of acceptance of the order.

NOTE Annex D gives more information on nodularity.

7.2.5 Matrix structure

Information regarding the matrix structure is given in Table E.1.

7.3 Solid solution strengthened ferritic spheroidal graphite cast irons

7.3.1 Test pieces machined from cast samples

The mechanical properties of solid solution strengthened ferritic spheroidal graphite cast iron test pieces shall be as specified in Table 3.

Table 3 — Mechanical properties measured on test pieces machined from cast samples for solid solution strengthened ferritic grades

Material designation		Relevant wall thickness	0,2 % proof strength	Tensile strength	Elongation
Symbol	Number	t mm	$R_{p0,2}$ MPa min	R_m MPa min	A % min
EN-GJS-450-18	5.3108	$t \leq 30$	350	450	18
		$30 \leq t \leq 60$	340	430	14
		$t > 60$	to be agreed upon between the manufacturer and the purchaser		
EN-GJS-500-14	5.3109	$t \leq 30$	400	500	14
		$30 \leq t \leq 60$	390	480	12
		$t > 60$	to be agreed upon between the manufacturer and the purchaser		
EN-GJS-600-10	5.3110	$t \leq 30$	470	600	10
		$30 \leq t \leq 60$	450	580	8
		$t > 60$	to be agreed upon between the manufacturer and the purchaser		

NOTE The mechanical properties of test pieces machined from cast samples may not reflect exactly the properties of the casting itself. Values for tensile properties of the casting are given in Annex B for guidance.

7.3.2 Test pieces machined from samples cut from a casting

If applicable, the manufacturer and the purchaser shall agree on:

- the location(s) on a casting where the sample(s) shall be taken;
- the mechanical properties that shall be measured;
- the minimum values, or allowable range of values, for these mechanical properties (for information, see Annex B).

NOTE The properties of castings may not be uniform, depending on the complexity of the castings and variation in their section thicknesses.

7.3.3 Hardness

Brinell hardness and its range values for the grades listed in Table 3 shall only be specified when agreed between the manufacturer and the purchaser by the time of acceptance of the order.

Information regarding hardness is given in Annex C.

7.3.4 Graphite structure

The graphite structure shall be mainly of form V and VI in accordance with EN ISO 945-1. A more precise definition may be agreed between the manufacturer and the purchaser.

NOTE 1 A.2.3 gives more information on graphite structure.

NOTE 2 Annex D gives more information regarding nodularity.

7.3.5 Matrix structure

Information on matrix structure is given in Table E.1 and A.2.2.

8 Sampling

8.1 General

Samples shall be made from the same material as that used to produce the casting(s) which they represent.

Several types of samples (separately cast samples, cast-on samples, side-by-side cast samples, samples cut from a casting) can be used, depending on the mass and wall thickness of the casting.

When relevant the type of sample should be agreed between the manufacturer and the purchaser. Unless otherwise agreed the choice of the option is left to the discretion of the manufacturer.

When the mass of the casting exceeds 2 000 kg and its relevant wall thickness 60 mm, cast-on samples or side-by-side samples should preferably be used; the dimensions and the location of the sample shall be agreed between the manufacturer and the purchaser by the time of acceptance of the order.

If the spheroidizing treatment is carried out in the mould (in-mould process), the separately cast sample should be avoided.

All samples shall be adequately marked to guarantee full traceability to the castings which they represent.

The samples shall be subject to the same heat treatment, as that of the castings they represent, if any.

Tensile and impact test pieces shall be finally machined from the samples after the heat treatment.

8.2 Cast samples

8.2.1 Size of cast sample

The size of the sample shall be in correspondence with the relevant wall thickness of the casting as shown in Table 4.

If other sizes are used, this shall be agreed between the manufacturer and purchaser.

Table 4 — Types and sizes of cast samples and sizes of tensile test pieces in relation to relevant wall thickness of the casting

Relevant wall thickness t mm	Type of sample				Preferred diameter of tensile test piece ^a d mm
	Option 1 U-shaped (see Figure 1)	Option 2 Y-shaped (see Figure 2)	Option 3 Round bar (see Figure 3)	Cast-on sample (see Figure 4)	
$t \leq 12,5$	—	I	Types b, c	A	7 (Option 3: 14 mm)
$12,5 < t \leq 30$	—	II	Types a, b, c	B	14
$30 < t \leq 60$	b	III	—	C	14
$60 < t \leq 200$	—	IV	—	D	14

^a Other diameters, in accordance with Figure 5, may be agreed between the manufacturer and the purchaser.
^b The cooling rate of this cast sample corresponds to that of a 40 mm thick wall.

8.2.2 Frequency and number of tests

Samples representative of the material shall be produced at a frequency in accordance with the process quality assurance procedures adopted by the manufacturer or as agreed with the purchaser.

In the absence of a process quality assurance procedure or any other agreement between the manufacturer and the purchaser, a minimum of one cast sample for the tensile test shall be produced to confirm the material grade, at a frequency to be agreed between the manufacturer and the purchaser.

When impact tests are required, samples shall be produced at a frequency to be agreed between the manufacturer and the purchaser.

8.2.3 Separately cast samples

The samples shall be cast separately in sand moulds and under representative manufacturing conditions.

The moulds used to cast the separately cast samples shall have comparable thermal behaviour to the moulding material used to cast the castings.

The samples shall meet the requirements of either Figures 1, 2 or 3.

The samples shall be removed from the mould at a temperature similar to that of the castings.

8.2.4 Side-by-side cast samples

Side-by-side cast samples are representative of the castings concurrently cast and also of all other castings of a similar relevant wall thickness from the same test unit.

When mechanical properties are required for a series of castings belonging to the same test unit, the side-by-side cast sample(s) shall be produced in the last mould(s) poured.

The samples shall meet the requirements of either Figures 1, 2 or 3.

8.2.5 Cast-on samples

Cast-on samples are representative of the castings to which they are attached and also of all other castings of a similar relevant wall thickness from the same test unit.

When mechanical properties are required for a series of castings belonging to the same test unit, the cast-on sample(s) shall be produced in the last mould(s) poured.

The sample shall have a general shape as indicated in Figure 4 and the dimensions shown therein.

The location of cast-on samples shall be agreed between the manufacturer and the purchaser by the time of acceptance of the order, taking into account the shape of the casting and the running system, in order to avoid any unfavourable effect on the properties of the adjacent material.

8.2.6 Test pieces machined from cast samples

The tensile test piece shown in Figure 5 and, if applicable, the impact test piece shown in Figure 6 shall be machined from a sample shown in Figure 3 or from the hatched part of Figures 1, 2 or 4.

The sectioning procedure for cast samples shall be in accordance with Annex G.

Unless otherwise agreed, the preferred diameter for the test piece shall be used.

8.3 Samples cut from a casting

In addition to the requirements of the material, the manufacturer and the purchaser may agree on the properties required (for information, see Annex B) at stated locations in the casting. These properties shall be determined by testing test pieces machined from samples cut from the casting at these stated locations.

The manufacturer and the purchaser shall agree on the dimensions of these test pieces.

In the absence of any directions by the purchaser, the manufacturer may choose the locations from which to cut the samples and the dimensions of the test pieces

The centreline of the test piece should be located at a point half way between the surface and the centre.

NOTE 1 When the zone of last solidification in the casting is included in the test piece diameter, the minimum elongation guidance value may not be obtained.

NOTE 2 In the case of large individual castings trepanned samples may be taken at agreed positions in the casting which are to be stated.

Dimensions in millimetres

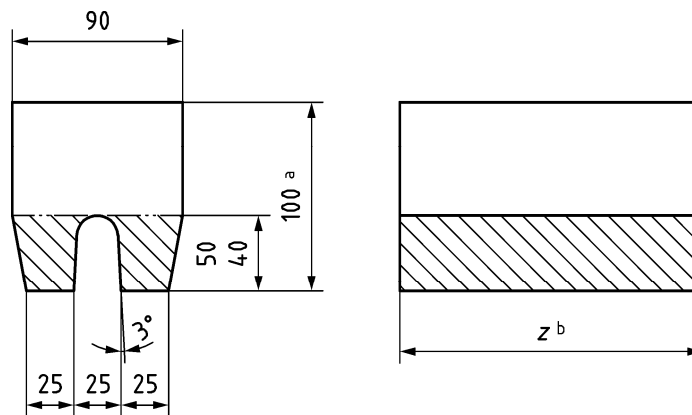

Key

^a For information only.

^b The length z shall be chosen to allow a test piece of dimensions shown in Figure 5 to be machined from the sample.

The thickness of the sand mould surrounding the samples shall be at least 40 mm.

Figure 1 — Separately cast or side-by-side cast samples — Option 1: U-shaped sample

.....

Dimensions in millimetres

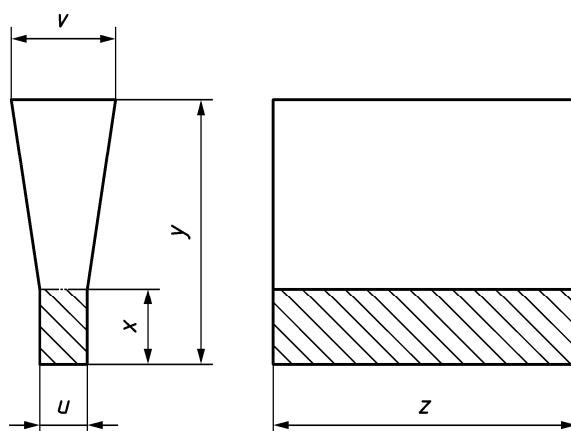

Dimension	Type			
	I	II	III	IV
u	12,5	25	50	75
v	40	55	100	125
x	25	40	50	65
y^a	135	140	150	175
z^b	A function of the test piece length			
^a	For information only.			
^b	z shall be chosen to allow a test piece of dimensions shown in Figure 5 to be machined from the cast sample.			

The thickness of the sand mould surrounding the samples shall be at least:

- 40 mm for types I and II;
- 80 mm for type III and IV.

Figure 2 — Separately cast or side by side cast samples — Option 2: Y-shaped sample

Dimensions in millimetres

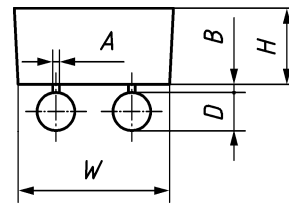
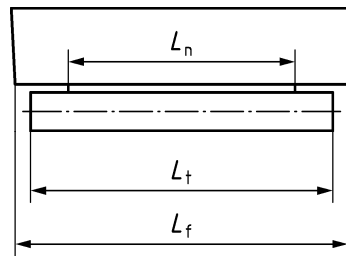

Type a

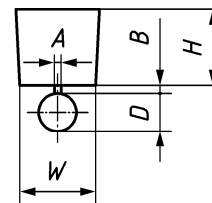
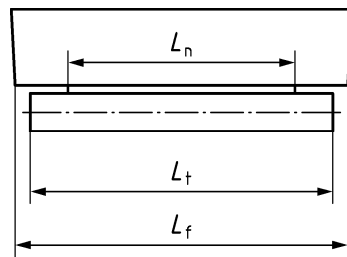

Type b

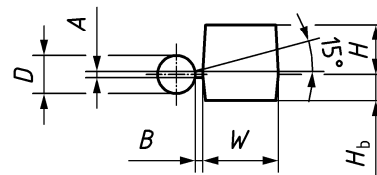
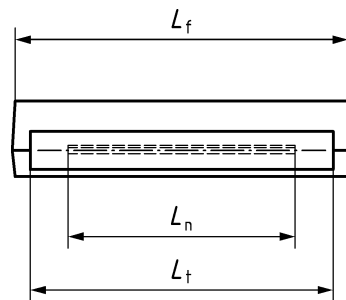

Type c

Type	A	B	D	H	H _b	L _f	L _n	L _t	W
a	4,5	5,5	25	50	—	L _t + 20	L _t - 50	a	100
b	4,5	5,5	25	50	—	L _t + 20	L _t - 50		50
c	4,0	5,0	25	35	15	L _t + 20	L _t - 50		50

^a L_t shall be chosen to allow a test piece of dimensions shown in Figure 5 to be machined from the cast sample.

The thickness of the sand mould surrounding the samples shall be at least 40 mm.

Figure 3 — Separately cast or side-by-side cast samples — Option 3: Round bar-shaped sample

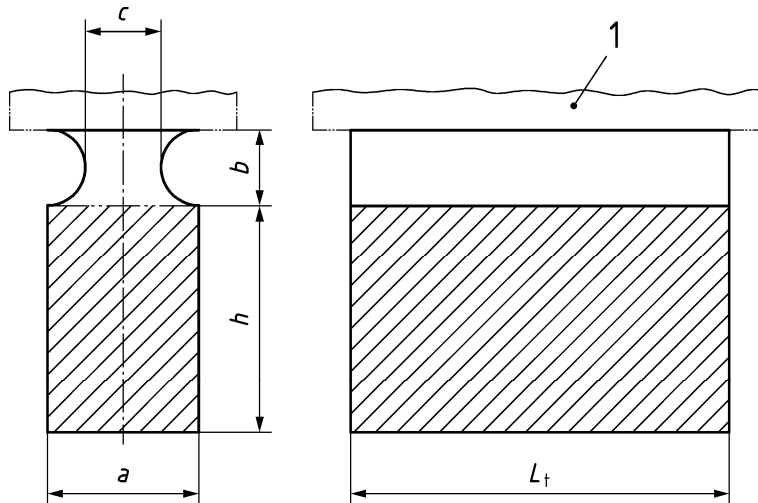

Key

1 casting

Dimensions in millimetres

Type	Relevant wall thickness of castings <i>t</i>	<i>a</i>	<i>b</i> max.	<i>c</i> min.	<i>h</i>	<i>L_t</i>
A	$t \leq 12,5$	15	11	7,5	20 to 30	a
B	$12,5 < t \leq 30$	25	19	12,5	30 to 40	
C	$30 < t \leq 60$	40	30	20	40 to 65	
D	$60 < t \leq 200$	70	52,5	35	65 to 105	

^a *L_t* shall be chosen to allow a test piece of a dimension shown in Figure 5 to be machined from the cast sample.

The thickness of the sand mould surrounding the samples shall be at least:

- 40 mm for types A and B;
- 80 mm for type C and D.

If smaller dimensions are agreed, the followings relationships apply:

$$b = 0,75 \times a$$

$$c = 0,5 \times a$$

Figure 4 — Cast-on samples

9 Test methods

9.1 Tensile test

The tensile test shall be carried out in accordance with EN ISO 6892-1:2009.

The preferred test piece diameter is 14 mm but, either for technical reasons or for test pieces machined from samples cut from the casting, it is permitted to use a test piece of different diameter (see Figure 5).

In all cases the original gauge length of the test piece shall conform to the equation:

$$L_o = 5,65 \times \sqrt{S_o} = 5 \times d$$

where

L_o is the original gauge length;

S_o is the original cross-section area of the test piece;

d is the diameter of the test piece along the gauge length.

If the above equation for L_o is not applicable, then an agreement shall be made between the manufacturer and the purchaser on the dimensions of the test piece to be made. A test piece with a different gauge length may be agreed upon between the manufacturer and the purchaser.

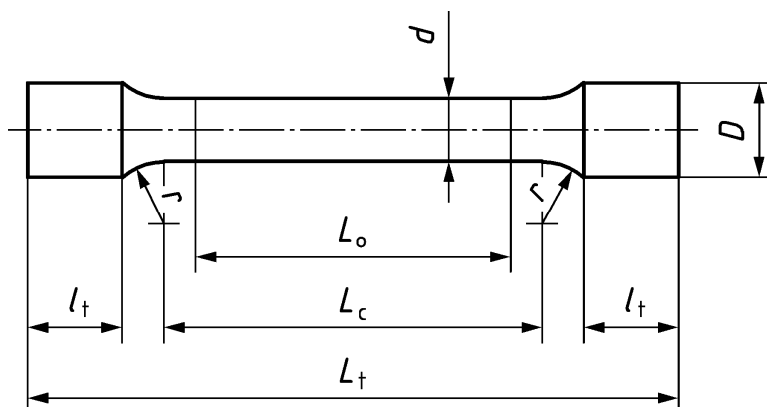

d	L_o	L_c min.
5	25	30
7	35	42
10	50	60
14 ^a	70	84
20	100	120

^a Preferred dimension for 25 mm cast sample diameter.

where

- L_o is the original gauge length, i.e. $L_o = 5 \times d$;
- d is the diameter of the test piece along the gauge length;
- L_c is the parallel length, $L_c > L_o$ (in principle, $L_c - L_o \geq d$);
- L_t is the total length of the test piece, which depends on L_c ;
- r is the transition radius, which shall be at least 4 mm.

NOTE The method of gripping the ends of the test piece, together with their length l_t may be agreed between the manufacturer and the purchaser.

Figure 5 — Tensile test piece

9.2 Impact test

The impact test shall be carried out on three Charpy V-notched impact test pieces (see Figure 6) in accordance with EN ISO 148-1:2010, using test equipment with an appropriate energy to determine the properties correctly.

Dimensions in millimetres

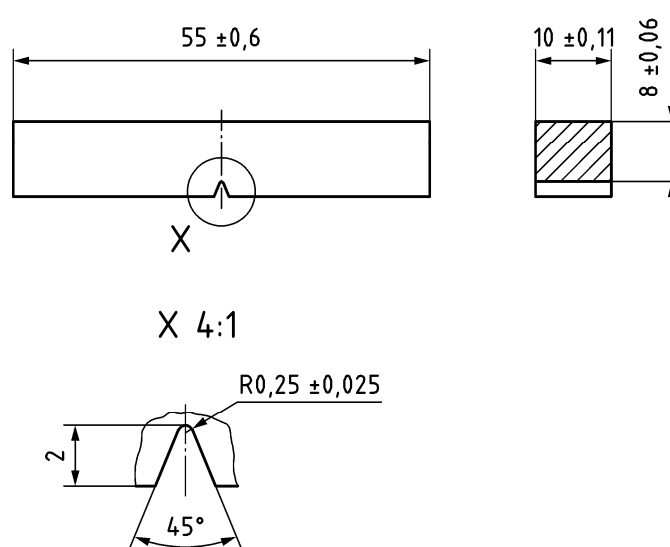

Figure 6 — Charpy V-notched impact test piece

9.3 Hardness test

The hardness shall be determined as Brinell hardness in accordance with EN ISO 6506-1.

Alternative hardness tests may also be agreed upon.

The test shall be carried out on the test pieces or at one or several points on the castings after preparation of the testing area in accordance with the agreement between the manufacturer and the purchaser.

If the measuring locations are not the subject of an agreement, they shall be chosen by the manufacturer. If it is not possible to carry out the hardness test on the casting, then by agreement between the manufacturer and the purchaser, the hardness test may be carried out on a knob cast-on to the casting.

9.4 Graphite structure examination

The graphite structure shall be confirmed by metallographic examination.

Non-destructive methods can also give information.

In case of dispute, the results of the microscopic examination shall prevail.

10 Retests

10.1 Need for retests

Retests shall be carried out if a test is not valid.

Retests are permitted to be carried out if a test result does not meet the mechanical property requirements for the specified grade.

10.2 Test validity

A test is not valid if there is:

- a) a faulty mounting of the test piece or defective operation of the test machine;
- b) a defective test piece because of incorrect pouring or incorrect machining;
- c) a fracture of the tensile test piece outside the gauge length;
- d) a casting defect in the test piece, evident after fracture.

In the above cases, a new test piece shall be taken from the same cast sample or from a duplicate sample cast at the same time, to replace those invalid test results.

10.3 Non-conforming test results

If any test gives results which do not conform to the specified requirements, for reasons other than those given in 10.2, the manufacturer shall have the option to conduct retests.

If the manufacturer conducts retests, two retests shall be carried out for each failed test.

If both retests give results that meet the specified requirements, the material shall be deemed to conform to this European Standard.

If one or both retests give results that fail to meet the specified requirements, the material shall be deemed not to conform to this European Standard.

10.4 Heat treatment of samples and castings

Unless otherwise specified, in the case of castings in the as-cast condition with mechanical properties not in conformance with this European Standard, a heat treatment may be carried out.

In the case of castings which have undergone a heat treatment and for which the test results are not valid or not satisfactory, the manufacturer shall be permitted to re-heat treat the castings and the representative samples. In this event, the samples shall receive the same number of heat treatments as the castings.

If the results of the tests carried out on the test pieces machined from the re-heat treated samples are satisfactory, then the re-heat treated castings shall be regarded as conforming to the specified requirements of this European Standard.

The number of re-heat treatment cycles shall not exceed two.

11 Inspection documentation

When requested by the purchaser and agreed with the manufacturer, the manufacturer shall issue for the products the appropriate inspection documentation according to EN 10204:2004.

When ordering material for pressure equipment applications, the equipment manufacturer has the obligation to request appropriate inspection documentation according to the applicable product or application standard(s), EN 764-5:2002 and EN 10204:2004.

The material manufacturer is responsible for affirming conformity with the specification for the material ordered.

Annex A (informative)

Additional information on solid solution strengthened ferritic spheroidal graphite cast irons

A.1 General

This informative annex applies to solid solution strengthened ferritic spheroidal graphite cast iron grades as specified in Table 3.

A.2 Material constitution

A.2.1 Chemical composition

In order to fulfil the requirements for the mechanical properties, a ferritic structure solid solution strengthened by silicon is recommended.

Table A.1 — Guidance values for chemical composition

Designation		Si	P	Mn
Symbol	Number	% approx. ^a	% max.	% max. ^b
EN-GJS-450-18	5.3108	3,20	0,05	0,50
EN-GJS-500-14	5.3109	3,80	0,05	0,50
EN-GJS-600-10	5.3110	4,30	0,05	0,50
^a Si content may be lower due to other alloying elements.				
^b With lower Mn content (e.g. 0,30 %), machinability and elongation will be improved.				

With increasing silicon content, the carbon content should be decreased correspondingly.

A.2.2 Matrix structure

The matrix should be predominantly ferrite with a maximum pearlite content of 5 %. The amount of free cementite should not exceed 1 %.

A.2.3 Graphite structure

The graphite structure should be mainly of form V and VI in accordance with EN ISO 945-1.

Due to the increased silicon content, these solid solution strengthened ferritic spheroidal graphite cast irons may show some compacted graphite (form III) in heavy sections. However ferritic matrices are, also for higher levels of solution strengthening by silicon, much less sensitive to reduced nodularity than cast irons strengthened by substantial amounts of pearlite.

A level of approximately 20 % of form III can be accepted, provided the remainder is mainly of form V and VI, to fulfil the minimum tensile properties specified in this European Standard.

A.3 Supplementary information

A.3.1 Application

These solid solution strengthened ferritic spheroidal graphite cast iron grades are used for applications where good machinability, high ductility and high proof strength are required.

A.3.2 Mechanical properties

A.3.2.1 0,2 % Proof strength

One of the characteristic properties of these solution strengthened ferritic spheroidal graphite cast irons is the high ratio "0,2 % proof strength/tensile strength" 75 % to 85 % as compared to of ratio for ferritic to pearlitic spheroidal graphite cast irons 55 % to 65 % (see Figure A.1).

Despite this higher ratio, elongation values are concurrently considerably higher for solid solution strengthened ferritic spheroidal graphite cast irons (compare Table 1 and Table 3).

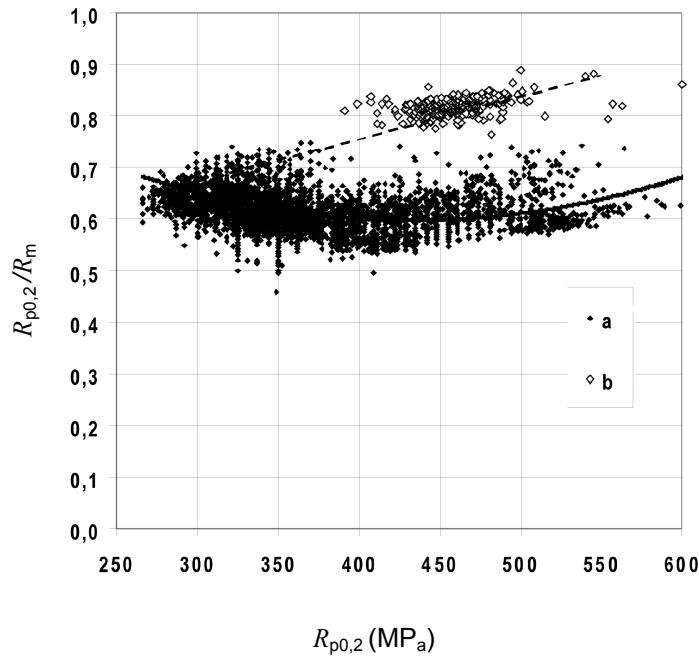

Key

- a ferritic, ferritic-pearlitic, pearlitic and ausferritic spheroidal graphite cast irons
- b solution strengthened ferritic spheroidal graphite cast irons

Figure A.1 — Spheroidal graphite cast irons — 25 mm cast samples — Ratio 0,2 % proof strength/tensile strength

Another characteristic property of these solid solution strengthened ferritic spheroidal graphite cast irons is that for an equal value in hardness, proof strength is significantly higher, as is shown in Figure A.2 (see also Table C.1).

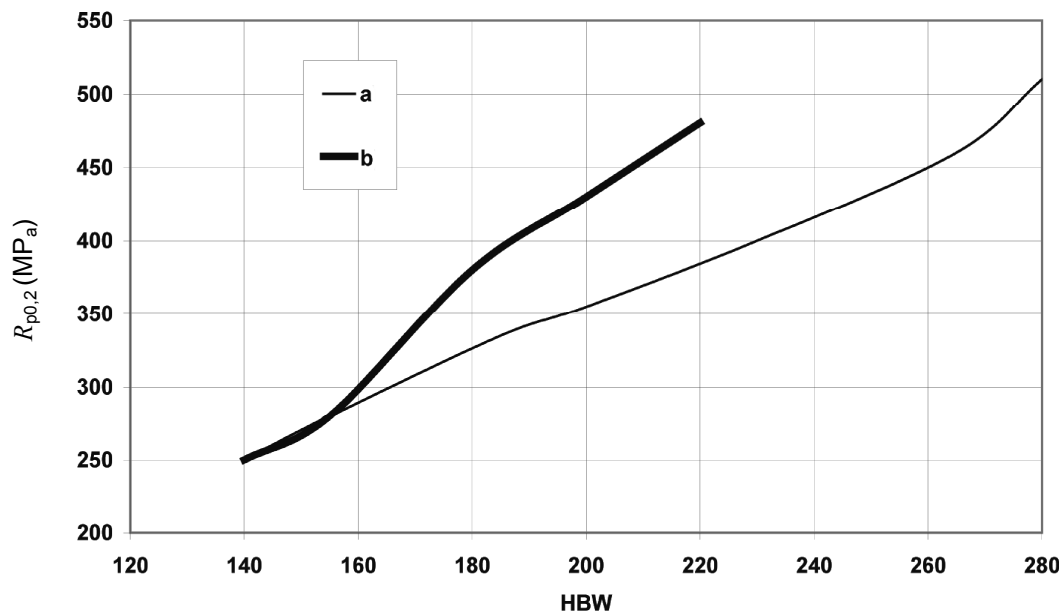

Key

- a ferritic, ferritic-pearlitic and pearlitic spheroidal graphite cast irons
- b solution strengthened ferritic spheroidal graphite cast irons

Figure A.2 — Spheroidal graphite cast irons — Relation between Brinell hardness and 0,2 % proof strength (curve based on the average values of this European Standard)

However, the relationship between tensile strength and Brinell hardness is more or less identical to that of the ferritic/pearlitic grades of spheroidal graphite cast irons, as is shown in Figure A.3.

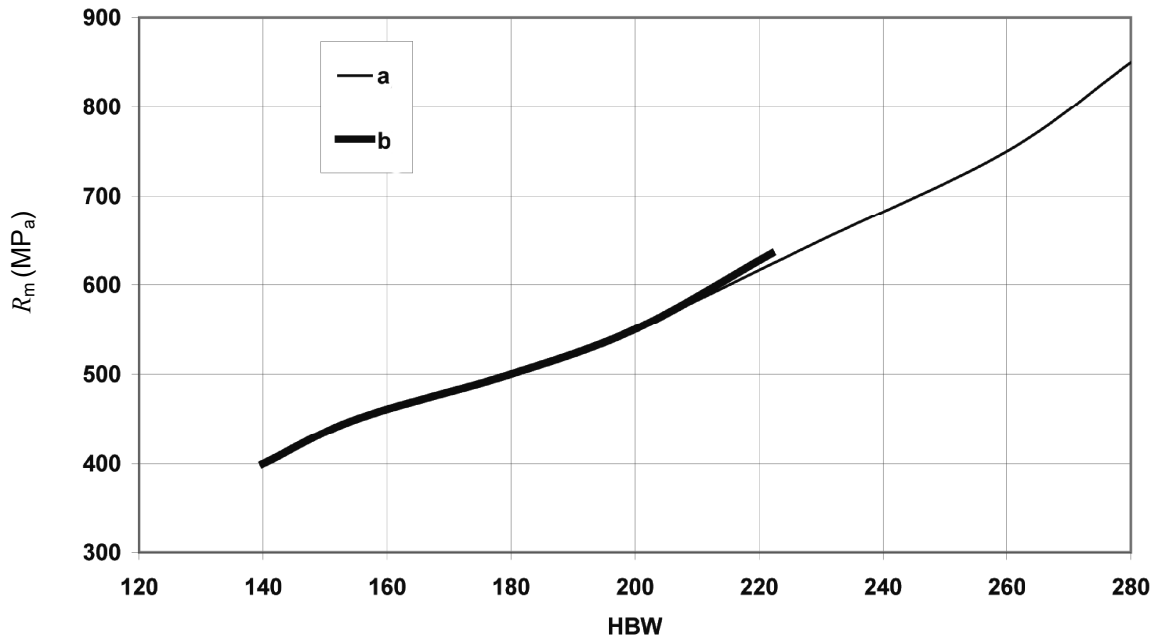

Key

- a ferritic, ferritic-pearlitic and pearlitic spheroidal graphite cast irons
- b solution strengthened ferritic spheroidal graphite cast irons

Figure A.3 — Spheroidal graphite cast irons — Relation between hardness and tensile strength (curve based on the average values of this European Standard)

A.3.2.2 Other mechanical and physical properties

For information see Annex E and Annex F.

A.3.3 Machinability

Compared to the corresponding ferritic/pearlitic grades, the solid solution strengthened ferritic spheroidal graphite cast iron grades exhibit considerably less hardness variation due to their single-phase matrix structure. For a same level of hardness, this reduction in hardness variation (see Table C.1), combined with a negligible amount of pearlite, results in improved machinability.

Annex B
(informative)

Guidance values for mechanical properties measured on test pieces machined from samples cut from the castings

Table B.1 — Guidance values for mechanical properties measured on test pieces machined from samples cut from the castings for ferritic to pearlitic grades

Material designation		Relevant wall thickness	0,2 % proof strength	Tensile strength	Elongation
Symbol	Number	t mm	$R_{p0,2}$ MPa min	R_m MPa min	A % min
EN-GJS-350-22C-LT	5.3100	$t \leq 30$	220	340	20
		$30 < t \leq 60$	210	320	15
		$60 < t \leq 200$	200	310	12
EN-GJS-350-22C-RT	5.3101	$t \leq 30$	220	340	20
		$30 < t \leq 60$	210	320	15
		$60 < t \leq 200$	200	310	12
EN-GJS-350-22C	5.3102	$t \leq 30$	220	340	20
		$30 < t \leq 60$	210	320	15
		$60 < t \leq 200$	200	310	12
EN-GJS-400-18C-LT	5.3103	$t \leq 30$	240	390	15
		$30 < t \leq 60$	230	370	12
		$60 < t \leq 200$	220	340	10
EN-GJS-400-18C-RT	5.3104	$t \leq 30$	250	390	15
		$30 < t \leq 60$	240	370	12
		$60 < t \leq 200$	230	350	10
EN-GJS-400-18C	5.3105	$t \leq 30$	250	390	15
		$30 < t \leq 60$	240	370	12
		$60 < t \leq 200$	230	350	10
EN-GJS-400-15C	5.3106	$t \leq 30$	250	390	12
		$30 < t \leq 60$	240	370	11
		$60 < t \leq 200$	230	350	8
EN-GJS-450-10C	5.3107	$t \leq 30$	300	440	8
		$30 < t \leq 60$	Guidance values to be provided by the manufacturer		
		$60 < t \leq 200$	Guidance values to be provided by the manufacturer		
EN-GJS-500-7C	5.3200	$t \leq 30$	300	480	6
		$30 < t \leq 60$	280	450	5
		$60 < t \leq 200$	260	400	3
EN-GJS-600-3C	5.3201	$t \leq 30$	360	580	3
		$30 < t \leq 60$	340	550	2
		$60 < t \leq 200$	320	500	1
EN-GJS-700-2C	5.3300	$t \leq 30$	410	680	2
		$30 < t \leq 60$	390	650	1
		$60 < t \leq 200$	370	600	1
EN-GJS-800-2C	5.3301	$t \leq 30$	460	780	2
		$30 < t \leq 60$	Guidance values to be provided by the manufacturer		
		$60 < t \leq 200$	Guidance values to be provided by the manufacturer		

In the case when the purchaser requires minimum mechanical property values to be obtained in a stated location of the casting, these values are to be agreed with the manufacturer.

Table B.2 — Guidance values for mechanical properties measured on test pieces machined from samples cut from the castings for solid solution strengthened ferritic grades

Material designation		Relevant wall thickness	0,2 % proof strength	Tensile strength	Elongation
Symbol	Number	t mm	$R_{p0,2}$ MPa min.	R_m MPa min.	A % min.
EN-GJS-450-18C	5.3108	$t \leq 30$	350	440	16
		$30 < t \leq 60$	340	420	12
		$60 < t \leq 200$	Guidance values to be provided by the manufacturer		
EN-GJS-500-14C	5.3109	$t \leq 30$	400	480	12
		$30 < t \leq 60$	390	460	10
		$60 < t \leq 200$	Guidance values to be provided by the manufacturer		
EN-GJS-600-10C	5.3110	$t \leq 30$	450	580	8
		$30 < t \leq 60$	430	560	6
		$60 < t \leq 200$	Guidance values to be provided by the manufacturer		

In the case when the purchaser requires minimum mechanical property values to be obtained in a stated location of the casting, these values are to be agreed with the manufacturer.

Annex C (informative)

Guidance values for hardness

C.1 General

When hardness is required in addition to the tensile properties, the procedure given in C.5 is recommended.

Table C.1 — Guidance values for Brinell hardness

Material designation		Brinell hardness range	
		HBW	
Symbol	Number	Relevant wall thickness t	
		$t \leq 60$ mm	$60 \text{ mm} < t \leq 200$ mm
EN-GJS-350-22	5.3102	less than 160	less than 160
EN-GJS-400-18	5.3105	130 to 175 ^a	130 to 175 ^a
EN-GJS-400-15	5.3106	135 to 180 ^a	135 to 180 ^a
EN-GJS-450-18	5.3108	170 to 200	160 to 190
EN-GJS-450-10	5.3107	160 to 210 ^a	160 to 210 ^a
EN-GJS-500-14	5.3109	185 to 215	170 to 200
EN-GJS-500-7	5.3200	170 to 230 ^a	150 to 230 ^a
EN-GJS-600-10	5.3110	200 to 230	190 to 220
EN-GJS-600-3	5.3201	190 to 270 ^a	180 to 270 ^a
EN-GJS-700-2	5.3300	225 to 305 ^a	210 to 305 ^a
EN-GJS-800-2	5.3301	245 to 335 ^a	240 to 335 ^a
EN-GJS-900-2	5.3302	270 to 360 ^a	270 to 360 ^a

NOTE 1 The lowest hardness is achieved with a ferritic matrix and low silicon content. The hardness increases with the amount of pearlite or increased silicon content.

NOTE 2 Eutectic carbides increase hardness but they are normally undesirable and only likely to be present in minor amounts.

^a By agreement between the manufacturer and the purchaser, a narrower hardness range may be adopted; a tolerance range of between 30 and 40 Brinell hardness units is commonly acceptable. This hardness range may be wider for grades with a ferritic-pearlitic matrix structure.

C.2 Sampling

Each hardness test should be carried out either on a casting or on a test piece at locations agreed between the manufacturer and the purchaser. In the absence of an agreement the test should be carried out at representative locations chosen by the manufacturer.

C.3 Test method

The hardness test should be carried out in accordance with EN ISO 6506-1.

If it is not possible to carry out the hardness test on the casting itself, then by agreement between the manufacturer and the purchaser, it may be carried out on a knob cast-on to the casting itself or on a separately cast sample.

If the test is carried out on a knob cast-on to the casting, it should not be separated before concluding any required heat treatment.

If the test is carried out on a test piece taken from a separately cast sample, this should be subjected firstly to any heat treatment required for the castings of which it is representative.

C.4 Number and frequency of hardness tests

The number and frequency of hardness tests can be the subject of an agreement between the manufacturer and the purchaser by the time of acceptance of the order.

C.5 Determination of a hardness range capable of meeting the tensile property requirements

This procedure applies mainly to serial production of castings, where it is possible to obtain the required number of samples.

This procedure is used to determine the hardness range of a material grade specified by its tensile properties according to Table 1 or Table 3 for a grade designated in Table C.1, for a particular foundry process.

- a) Select the hardness grade from Table C.1.
- b) Select the corresponding grade in Table 1 or Table 3 and the type of sample using the values shown in Table C.1 for tensile strength and 0,2 % proof strength of the specified hardness grade.
- c) Retain only those test pieces with a value within the hardness range for the selected grade, see a).
- d) Determine tensile strength, 0,2 % proof strength, elongation and Brinell hardness values for each test piece. Round hardness values to the nearest 10 HBW. As agreed between the manufacturer and the purchaser, in order to obtain the desired statistical confidence, conduct as many tests as are necessary to obtain a minimum number of values of tensile strength for each HBW value.
- e) Plot histograms of tensile properties, as a function of hardness.
- f) For each HBW value, take the minimum value of each tensile property as the process capability indicator.
- g) Specify as the minimum HBW value the minimum hardness for which tensile strength and 0,2 % proof strength meet the requirements of the grade specified in Table 1 or Table 3.
- h) Specify as the maximum HBW value the maximum hardness for which the elongation meets the requirements of the grade specified in Table 1 or Table 3.

The hardness range lies between the minimum and the maximum HBW values as determined by the above procedure.

Annex D (informative)

Nodularity

The nodularity of spheroidal graphite cast irons is defined as the percentage of graphite particles that are spheroidal or nodular in shape (form V and VI of EN ISO 945-1).

While the number of particles is detected by $100\times$ magnification, the determination of the form and its percentage should be done with a magnification which shows the graphite particles in approximately the size according to EN ISO 945-1:2008, Figure 1. While the classification of the graphite form is accomplished on the basis of this standard in comparison to reference pictures, the computer aided image analysis with specific software parameters might be applied for this material as well.

Nodularity not only depends on the production process influenced, for example, by the chemical composition, the remaining magnesium concentration or the inoculation method, but also on the solidification rate of the melt in the respective wall areas. Furthermore, it is possible to influence the graphite form in the contact area of the mould area as well.

The nodule roundness marks only one aspect of the material quality. Further parameters influencing the material qualities are, among others, the number of graphite particles and their distribution, the pearlite concentration and its arrangement, the solid solution strengthening of the ferrite and possible microshrinkage. Concerning the guarantee of the minimum material properties specified in this standard, it is therefore impossible to define precise standards of nodularity for certain solidification modulus.

However, experience shows that a nodularity of 80 % or more generally ensures the minimum tensile properties specified in this European Standard, as long as the matrix of the chosen variety is adjusted accordingly. Most of the 15 % to 20 % of graphite not being in form V and VI is then in form IV and possibly in form III (and may even be of form II in thick walled castings). See also A.2.3.

For castings subjected to severe loading, in particular under fatigue conditions, a higher nodularity (including requirements for a specific percentage of form V and VI graphite) may be required, especially for ferritic-pearlitic to pearlitic grades. Such a requirement should be evaluated by an experimental study, specific to the casting and the material grade.

Ultrasonic velocity and sound resonance frequency are influenced by graphite structure. Their measurement, after calibration, can give information on nodularity. However, this measurement cannot replace metallographic examination.

Annex E (informative)

Additional information on mechanical and physical properties

Information on mechanical and physical properties is given in Table E.1 (in addition to that given in Tables 1 and 3).

Table E.1 — Typical properties ^a

Characteristic	Unit	Material designation										
		EN-GJS-350-22	EN-GJS-400-18	EN-GJS-450-10	EN-GJS-500-7	EN-GJS-600-3	EN-GJS-700-2	EN-GJS-800-2	EN-GJS-900-2	EN-GJS-450-18	EN-GJS-500-14	EN-GJS-600-10
Shear strength	MPa	315	360	405	450	540	630	720	810	-	nd ^b	-
Torsional strength	MPa	315	360	405	450	540	630	720	810	-	nd ^b	-
Modulus of elasticity <i>E</i> (tension and compression)	GN/m ²	169	169	169	169	174	176	176	176	170	170	170
Poisson's ratio ν	—	0,275	0,275	0,275	0,275	0,275	0,275	0,275	0,275	0,28 to 0,29	0,28 to 0,29	0,28 to 0,29
Fatigue limit ^c (rotating bending) unnotched ^d (ϕ 10,6 mm)	MPa	180	195	210	224	248	280	304	304	210	225	275
Fatigue limit ^c (rotating bending) notched ^e (ϕ 10,6 mm)	MPa	114	122	128	134	149	168	182	182	130	140	165
Compression strength	MPa	—	700	700	800	870	1 000	1 150	—	-	nd ^b	-
Fracture toughness ^{g,h,i} K_{IC}	MPa · \sqrt{m}	90	82	72	63	38	30	30	30	75	72	65
Thermal conductivity at 300 °C	W/(K·m)	36,2	36,2	36,2	35,2	32,5	31,1	31,1	31,1	-	-	-
Specific heat capacity 20 °C to 500 °C	J/(kg·K)	515	515	515	515	515	515	515	515	-	-	-
Linear expansion coefficient 20 °C to 400 °C	$\mu m/(m \cdot K)$	12,5	12,5	12,5	12,5	12,5	12,5	12,5	12,5	-	-	-
Mass Density	kg/dm ³	7,1	7,1	7,1	7,1	7,2	7,2	7,2	7,2	7,1	7,0	7,0
Maximum permeability	$\mu H/m$	2 136	2 136	2 136	1 596	866	501	501	501	nd ^b	nd ^b	nd ^b
Hysteresis loss (B = 1T)	J/m ³	600	600	600	1 345	2 248	2 700	2 700	2 700	nd ^b	nd ^b	nd ^b
Resistivity	$\mu\Omega \cdot m$	0,50	0,50	0,50	0,51	0,53	0,54	0,54	0,54	nd ^b	nd ^b	nd ^b
Matrix structure		ferrite	ferrite	ferrite	ferrite-pearlite	pearlite-ferrite	pearlite	pearlite or tempered martensite	martensite or tempered bainite ^f	ferrite	ferrite	ferrite

- ^a Unless otherwise specified, the values given in this table come from measurements at room temperature.
- ^b Not determined.
- ^c Fatigue limit test pieces according to Wöhler.
- ^d Unnotched – In annealed ferritic spheroidal graphite cast irons the fatigue limit is about 0,5 × tensile strength in spheroidal graphite cast irons with a tensile strength of 370 MPa. The ratio decreases with increase in tensile strength until, in pearlitic and quenched and tempered spheroidal graphite cast irons, the fatigue limit is approximately 0,4 × tensile strength. The ratio decreases further when tensile strength exceeds 740 MPa. This ratio remains at around 0,45 in solid solution strengthened ferritic grades also at the higher tensile strengths.
- ^e Notched – For a test piece of 10,6 mm diameter at notch with a circumferential 45° V-notch having a radius of 0,25 mm, the fatigue limit of annealed spheroidal graphite cast irons decreases to a value of about 0,63 × fatigue limit of unnotched test pieces in spheroidal graphite cast irons with a tensile strength of 370 MPa.
- ^f For large castings, it can also be pearlite.
- ^g Values for 25 mm cast samples; higher values should be expected for thicker walled castings.
- ^h K_{IC} values given for as-cast conditions. Spheroidal graphite cast irons ferritized by heat treatment present lower toughness [12].
- ⁱ K_{IC} values are based on [12], [15] and [22].

Annex F (informative)

Fracture toughness, impact energy and ductility of spheroidal graphite cast irons

F.1 General

The mechanical properties of spheroidal graphite cast irons are governed by four factors:

- the matrix microstructure where the type (as-cast fully ferritic, ferritic-pearlitic or fully pearlitic) and fineness govern the structural strengthening effect from pearlite,
- the degree of solid solution strengthening of the matrix ferrite (also within any pearlite) due to the level of silicon in the ternary Fe-C-Si base alloy and the levels of other suitable elements,
- the graphite morphology (nodularity and nodule count), and
- the occurrence of imperfections.

Like most ferrous metals, spheroidal graphite cast irons exhibit fracture behaviour which also varies according to temperature, stress state and strain rate.

F.2 Fracture mechanics

With the fracture mechanics concept, the allowable component stress and the size of structural imperfections are quantitatively linked together through the fracture toughness, a material property which characterises the resistance to unstable crack propagation. An imperfection of critical size at a certain stress level leads to unstable crack propagation and rapid failure under static loading, i.e. brittle fracture. Cyclic loading may cause slow and stable crack extension, or fatigue cracking, prior to final failure. The aim of a fracture mechanics analysis is to determine critical crack (or imperfection) sizes being sufficient for failure at certain stress levels.

Linear-elastic Fracture Mechanics (LEFM) allows experimental determination of an intrinsic material property called the plane strain fracture toughness K_{IC} ; it has the unit $\text{MPa}\cdot\sqrt{m}$ and it can be used in design calculations. Once known, for each given stress level a critical crack size can be calculated quantitatively. Alternatively, for a certain crack size, a permissible stress level can be calculated [13].

For materials being ductile at room temperature such as most spheroidal graphite cast irons, the LEFM concept applies only at low temperatures, at high loading rates or when embrittlement occurs, e.g. due to large wall thickness. In the latter case the resulting tri-axial stress state, associated with plane strain conditions, reduces the size of the crack tip plastic zone by a factor of three in relation to the plane stress bi-axial plastic zone characteristic of a thin wall. A tri-axial stress state enhances the brittle behaviour of a material, while a bi-axial or plane stress state promotes plastic deformation and ductile behaviour [13].

Elastic Plastic Fracture Mechanics (EPFM), (or non-linear FM), offers the most general concept, the J -integral, particularly for non-linear materials, but applies as well to quasi-linear and linear materials. The direct measurement of K_{IC} at room temperature and at higher temperatures is difficult for spheroidal graphite cast irons, since it requires large test pieces to suppress plastic deformation, especially in the tougher grades. For this reason, values of K_{IC} are normally deduced from the measurement of J_{IC} . Measured J_{IC} values (given in kJ/m^2) can then be converted to K_{IC} (in $\text{MPa}\cdot\sqrt{m} = 10^6 \text{ N}\cdot\text{m}^{-1,5}$) using the relation $J_{IC} = K_{IC}^2 \cdot E^{-1} \cdot (1-\nu^2)$ [13].

Instrumented notched bar impact tests can be used to determine a dynamic fracture toughness parameter K_{ID} .

Advances in fracture mechanics have led to safe fracture-resistant design using FMBD (Fracture Mechanics Based Design) approaches. Instead of merely avoiding temperatures where brittle failure is probable under certain severe loading conditions (not necessarily being relevant for the actual design case), FMBD may be used to determine if brittle fracture is a possible failure mode. One demanding application, where FMBD has enabled the qualification of spheroidal graphite cast iron, is in transport containers for radioactive material [14] [23].

F.3 Fracture toughness

According to Table E.1, the K_{ID} levels for ferritic to pearlitic grades decrease from $90 \text{ MPa} \cdot \sqrt{m}$ for fully ferritic to $30 \text{ MPa} \cdot \sqrt{m}$ for fully pearlitic. Previous values cited in earlier versions of this European Standard were 2 to 3 times lower due to the initial use of specimen sizes being insufficient for LEFM [15].

Information on the influence of silicon content on fracture toughness is given in [17].

Fracture toughness determination by J_{IC} (determined at low strain rate and converted to K_{IC}) confirms a slow decrease in toughness for ferritic matrices with increasing Si content and corresponding strength level. However, at the same intermediate tensile strength level (500 MPa), Si-solution strengthened ferritic is indeed *tougher* than ferritic-pearlitic ($72 \text{ MPa} \cdot \sqrt{m}$ vs. $63 \text{ MPa} \cdot \sqrt{m}$), see grey bars in Figure F.1.

A similar slow decrease in toughness is observed using K_{ID} and in this case the K_{ID} levels (where specimen size was insufficient for LEFM) are equal for the two spheroidal graphite cast irons of intermediate tensile strength [17], see black diamonds in Figure F.1.

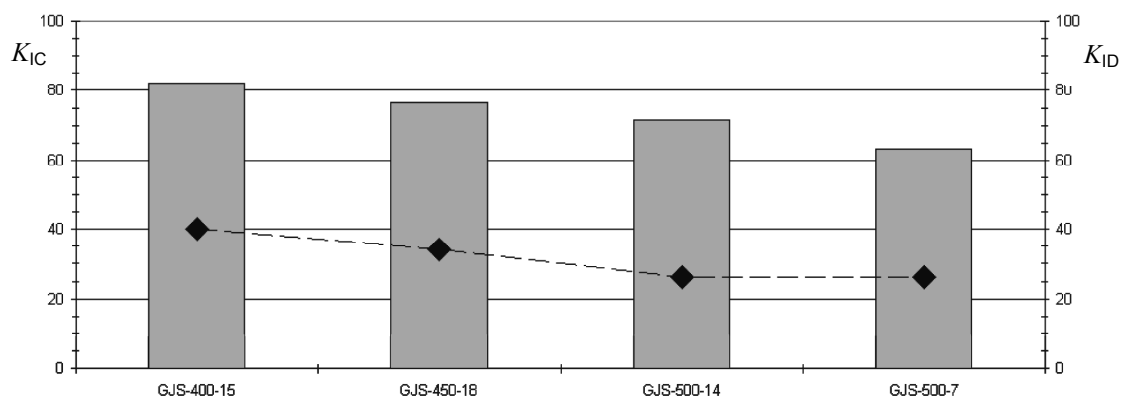

Figure F.1 — Comparison of fracture toughness as determined by K_{IC} [MPa·√m] (grey bars) based on J_{IC} and by K_{ID} [MPa·√m] (black diamonds) between three fully ferritic spheroidal graphite cast irons, solid solution strengthened with increasing silicon content (up to 3,8 % Si), compared to a ferritic-pearlitic spheroidal graphite cast iron of intermediate tensile strength [17] on the right

F.4 Impact energy

F.4.1 V-notched impact test

The Charpy V-notched impact test has since long been the most common method of determining resistance to brittle fracture. The method measures the absorbed total impact energy [in J] (or notched bar impact energy) for crack initiation and propagation to final fracture [13].

The impact energy test was initially developed to monitor the ductile to brittle fracture transition in sheet steel at low temperatures. The method has, mainly due to simplicity and low cost, subsequently been uncritically adopted as a general method and applied far beyond its scope of application.

The impact energy is measured in Joules ($J = N \cdot m$), while toughness is measured in $MPa \cdot \sqrt{m}$ ($= 10^6 N \cdot m^{-1.5}$), and strength is measured in MPa ($= 10^6 N \cdot m^{-2}$), illustrating the close relationship between toughness and strength units.

Main reasons for preferring fracture toughness instead of impact energy for evaluating castings are threefold:

- a) The strain rate ($540 s^{-1}$) caused by the impact hammer at the V-notch is about four orders of magnitude higher than strain rates ($\leq 0,06 s^{-1}$) encountered in common severe applications [16].
- b) Castings are almost always large enough to be loaded under plane strain conditions, as opposed to plane stress conditions in thin sections where contraction constraint is absent [13].

These differences (stress state and strain rate) may unfortunately shift the brittle-to-ductile transition temperature upwards by more than 100 K, concealing the actual ductile behaviour experienced in applications [15], [18].

- c) The impact energy in Joules cannot be used in design calculations [13].

It is well known that an increased Si level reduces the impact energy of spheroidal graphite cast irons. However, impact behaviour is similar for ferritic EN-GJS-500-14 and ferritic-pearlitic EN-GJS-500-7 grades [17], see Figure F.2.

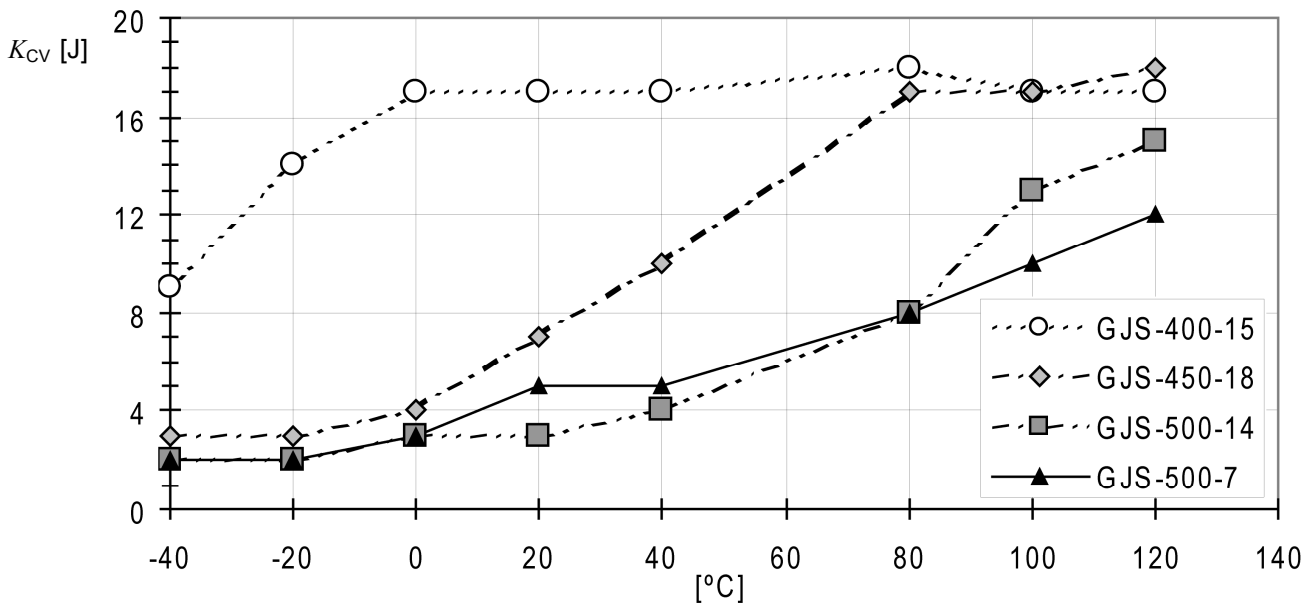

Figure F.2 — Comparison of impact energies (Charpy V-notch) at various temperatures between three fully ferritic spheroidal graphite cast irons, solid solution strengthened with increasing silicon content (up to 3,8 % Si), and a ferritic-pearlitic spheroidal graphite cast iron of intermediate tensile strength [17]

Further information about impact energy and fracture toughness of spheroidal graphite cast irons compared to other cast materials is given in [15], [18], [19] and [20].

F.4.2 Un-notched impact test

Impact energy testing using un-notched Charpy test pieces at RT is commonly used as an indirect method to determine conformance to the required microstructure after austempering (ADI) heat treatment, but the method is also increasingly used for as-cast spheroidal graphite cast irons to reveal any transition in fractographic mode from cleavage (brittle) to microvoid coalescence (ductile) due to changes in temperature [20].

Annex I gives values of un-notched impact energy values for several grades of spheroidal graphite cast irons. For the same ultimate tensile strength, it shows that Si-solution strengthened ferritic cast irons present higher values of this parameter.

F.5 Fracture elongation

The fracture elongation A_5 [%] which is a measure of tensile ductility (plastic strain after fracture) may, when K_{IC} data is missing, provide the second best information about the resistance to brittle fracture, at least for the low or intermediate strain rates commonly encountered in various applications.

It has been found that in as-cast spheroidal graphite irons, increasing the strength level through solid solution strengthening of a ferritic matrix by an increased amount of silicon reduces the ductility far less than is the case for conventional structural strengthening, relying on an increased amount of pearlite to attain the same tensile strength level [16].

Related to this, it is also clear that the limit for an acceptable level of graphite nodularity can be much lower in ferritic grades than in pearlitic grades, and that the tolerance for poor nodularity is much greater in ferritic grades [21], at least in static loading. One example demonstrating that this is valid also for ferritic matrices having higher levels of solid solution strengthening by silicon can be found in [16].

Annex G
(normative)

Sectioning procedure for cast samples

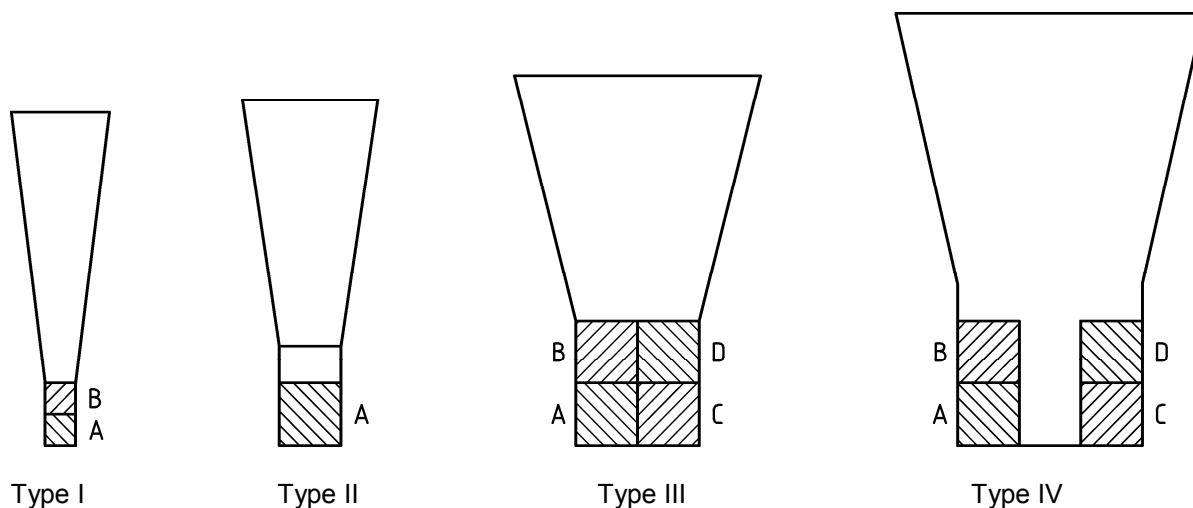

Figure G.1 — Sectioning procedure for Y-shaped samples Type I, Type II, Type III and Type IV (see Figure 2)

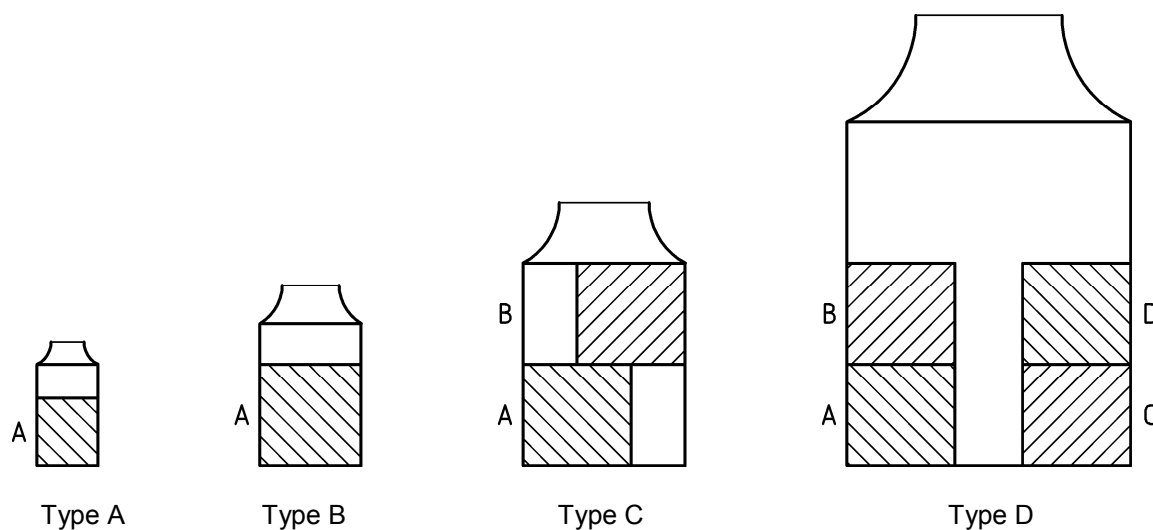

Figure G.2 — Sectioning procedure for cast-on samples Type A, Type B, Type C and Type D (see Figure 4)

Annex H (informative)

Comparison of spheroidal graphite cast iron material designations according to EN 1560 [1] and ISO/TR 15931 [24]

This informative annex compares the material designations of the standardized grades of spheroidal graphite cast iron based on the ISO and EN designation systems.

Table H.1 — Material designations of spheroidal graphite cast irons — Classification based on mechanical properties measured on machined test pieces prepared from cast samples

EN 1563:2011, Table 1 and Table 3		EN 1563:1997		ISO 1083:2004 [11]	
Symbol	Number	Table 1	Table 3	Table 1 and A.1	Table 3 and A.1
EN-GJS-350-22-LT	5.3100	EN-JS1015	EN-JS1019	ISO 1083/JS/350-22-LT/S	ISO 1083/JS/350-22-LT/U
EN-GJS-350-22-RT	5.3101	EN-JS1014	EN-JS1029	ISO 1083/JS/350-22-RT/S	ISO 1083/JS/350-22-RT/U
EN-GJS-350-22	5.3102	EN-JS1010	EN-JS1032	ISO 1083/JS/350-22/S	ISO 1083/JS/350-22/U
EN-GJS-400-18-LT	5.3103	EN-JS1025	EN-JS1049	ISO 1083/JS/400-18-LT/S	ISO 1083/JS/400-18-LT/U
EN-GJS-400-18-RT	5.3104	EN-JS1024	EN-JS1059	ISO 1083/JS/400-18-RT/S	ISO 1083/JS/400-18-RT/U
EN-GJS-400-18	5.3105	EN-JS1020	EN-JS1062	ISO 1083/JS/400-18 /S	ISO 1083/JS/400-18 /U
EN-GJS-400-15	5.3106	EN-JS1030	EN-JS1072	ISO 1083/JS/400-15 /S	ISO 1083/JS/400-15 /U
EN-GJS-450-18	5.3108	—	—	—	—
EN-GJS-450-10	5.3107	EN-JS1040	EN-JS1132	ISO 1083/JS/450-10 /S	ISO 1083/JS/450-10 /U
EN-GJS-500-14	5.3109	—	—	—	—
—	—	—	—	ISO 1083/JS/500-10 /S	ISO 1083/JS/500-10 /U
EN-GJS-500-7	5.3200	EN-JS1050	EN-JS1082	ISO 1083/JS/500-7 /S	ISO 1083/JS/500-7 /U
—	—	—	—	ISO 1083/JS/550-5 /S	ISO 1083/JS/550-5 /U
EN-GJS-600-10	5.3110	—	—	—	—
EN-GJS-600-3	5.3201	EN-JS1060	EN-JS1092	ISO 1083/JS/600-3 /S	ISO 1083/JS/600-3 /U
EN-GJS-700-2	5.3300	EN-JS1070	EN-JS1102	ISO 1083/JS/700-2 /S	ISO 1083/JS/700-2 /U
EN-GJS-800-2	5.3301	EN-JS1080	EN-JS1112	ISO 1083/JS/800-2 /S	ISO 1083/JS/800-2 /U
EN-GJS-900-2	5.3302	EN-JS1090	EN-JS1122	ISO 1083/JS/900-2 /S	ISO 1083/JS/900-2 /U

Annex I (informative)

Un-notched impact test

I.1 Impact energy values

The minimum impact energy values for the different material grades should be as specified in Table I.1 and Table I.2. These values apply to cast sample with a thickness or diameter of 25 mm.

Table I.1 — Un-notched impact energy values for ferritic to-pearlitic grades of spheroidal graphite cast iron

Material designation	Minimum impact energy values at 23 °C ± 5 °C J
EN-GJS-350-22/22-RT/22-LT	120
EN-GJS-400-18/18-RT/18-LT	120
EN-GJS-400-15	100
EN-GJS-450-10	80
EN-GJS-500-7	70
EN-GJS-600-3	40
EN-GJS-700-2	20
EN-GJS-800-2	15

Table I.2 — Un-notched impact energy values for solution strengthened ferritic grades of spheroidal graphite cast iron

Material designation	Minimum impact energy values at 23 °C ± 5 °C J
EN-GJS-450-18	100
EN-GJS-500-14	80
EN-GJS-600-10	70

I.2 Test piece

The impact test pieces should be prepared to dimensions according to Figure 6, but without the notch.

I.3 Test method

The impact test should be carried out on four un-notched test pieces based on EN ISO 148-1, using test equipment with an appropriate energy to determine the properties correctly.

The lowest impact energy value should be discarded, and the average of the three remaining values should be used.

I.4 Retests

Retests should be permitted and carried out under the same conditions as those specified in Clause 10.

Annex J (informative)

Significant technical changes between this European Standard and the previous edition

Table J.1 — Significant technical changes between this European Standard and the previous edition

Clause/paragraph/table/figure	Change
1	Addition of solid solution strengthened ferritic spheroidal graphite cast iron grades.
3	Definitions added: ferritic to pearlitic spheroidal graphite cast iron, solid-solution strengthened ferritic spheroidal graphite cast iron, cast sample, separately cast sample, side-by-side cast sample, cast-on sample and relevant wall thickness.
7	Mechanical properties are wall thickness dependant as shown in Tables 1, 2 and 3.
7	Classification as a function of hardness (Annex A from the EN 1563:1997) was withdrawn; Annex C gives guidance values for hardness of different grades.
7.2, Tables 1 and 2	Structure of designation by numbers has been changed.
7.2.1.1, Table 1	Ferritic to pearlitic spheroidal graphite cast irons: the required minimum mechanical properties applies to several types of cast samples and are given for 3 ranges of relevant wall thickness.
7.2.1.2, Table 2	Ferritic to pearlitic spheroidal graphite cast irons: the minimum impact energy values applies to several types of cast samples and are given for 3 ranges of relevant wall thickness.
7.3.1, Table 3	Solid solution strengthened ferritic spheroidal graphite cast irons: the required minimum mechanical properties applies to several types of cast samples and are given for 3 ranges of relevant wall thickness.
8.2.1, Table 4	Types and sizes of cast samples and sizes of tensile test pieces are given in relation to relevant wall thickness of the casting.
Annex A	Informative Annex A giving additional information on solid solution strengthened ferritic spheroidal graphite cast irons added
Annex B	Informative Annex B (Annex D from the EN 1563:1997) where guidance values for mechanical properties measured on test pieces machined from a casting are given for 3 ranges of relevant wall thickness.
Annex C	Informative Annex C giving guidance values for hardness.

Table J.1 (continued)

Clause/paragraph/table/figure	Change
Annex D	Informative Annex D with information regarding the nodularity added.
Annex E	<p>Informative Annex E (Annex B from the EN 1563:1997) where the additional information on mechanical and physical properties of the solid solution strengthened ferritic spheroidal graphite cast iron grades are also given.</p> <p>The normative Annex E: "Formation of test units and number of test" from the EN 1563:1997 version was withdrawn.</p>
Annex F	Informative Annex F where the toughness (resistance to crack propagation under a given stress) is presented, discussed and compared with impact energy added.
Annex G	Normative Annex G for the sectioning procedure of cast samples added.
Annex H	Informative Annex H for the comparison of spheroidal graphite cast iron material designations according to EN 1560 and ISO/TR 15931 added.
Annex I	Informative Annex I with details regarding the un-notched impact test added.
<p>NOTE The technical changes referred include the significant technical changes from the EN revised but is not an exhaustive list of all modifications from the previous version.</p>	

Annex ZA (informative)

Relationship between this European Standard and the Essential Requirements of EC Directive 97/23/EC

This European Standard has been prepared under a mandate given to CEN by the European Commission and the European Free Trade Association to provide means of conforming to Essential Requirements of the New Approach Directive 97/23/EC.

Once this standard is cited in the Official Journal of the European Union under that Directive and has been implemented as a national standard in at least one Member State, compliance with the clauses of this standard given in Table ZA.1 confers, within the limits of the scope of this standard, a presumption of conformity with the corresponding Essential requirements of that Directive and associated EFTA regulations.

For this harmonized supporting standard for materials, presumption of conformity to the Essential Requirements of the Directive is limited to technical data of the material in the standard and does not presume adequacy of the material to the specific equipment. Consequently the technical data stated in the material standard should be assessed against the design requirements of the specific equipment to verify that the Essential Requirements of the Pressure Equipment Directive (PED) are satisfied.

Table ZA.1 — Correspondence between EN 1563 and Pressure Equipment Directive 97/23/EC

Clause(s) / subclause(s) of this European Standard	Subject	Qualifying remarks/Notes
Tables 1, 2 and 3	Material properties	Annex I, 4.1 a) of the Directive
11	Conformity of material and manufacturer's certified documentation	Annex I, 4.3 of the Directive

WARNING — Other requirements and other EU Directives may be applicable to the product(s) falling within the scope of this standard.

Bibliography

- [1] EN 1560, *Founding — Designation system for cast iron — Material symbols and material numbers*
- [2] EN 10027-2, *Designation systems for steels — Part 2: Numerical system*
- [3] EN 1559-1, *Founding — Technical conditions of delivery — Part 1: General*
- [4] EN 1559-3, *Founding — Technical conditions of delivery — Part 3: Requirements for iron castings*
- [5] EN 1564, *Founding — Austempered ductile cast irons*
- [6] EN 16124, *Founding — Low-alloyed ferritic spheroidal cast iron for elevated temperature applications*
- [7] EN 13835, *Founding — Austenitic cast irons*
- [8] EN 545, *Ductile iron pipes, fittings, accessories and their joints for water pipelines — Requirements and test methods*
- [9] EN 598, *Ductile iron pipes, fittings, accessories and their joints for sewerage applications — Requirements and test methods*
- [10] EN 969, *Ductile iron pipes, fittings, accessories and their joints for gas pipelines — Requirements and test methods*
- [11] ISO 1083:2004, *Spheroidal graphite cast irons — Classification*
- [12] Reynaud, A., "Influence of ferritization on damage mechanism of spheroidal graphite cast irons", *Fonderie Fondateur d'Aujourd'hui*, March 2000, p 23-28
- [13] Hertzberg, R.W., Chapter 8-9 in "Deformation and Fracture Mechanics of Engineering Materials", 4th Ed., John Wiley & Sons, 1996, ISBN 978-0-471-01214-6
- [14] Smith, J.A., Salzbrenner, D., Sorenson, K., and McConnell, P., "Fracture Mechanics Based Design for Radioactive Material Transport Packagings", Sandia Report SAND98-0764, Sandia Natl. Labs, April 1998
- [15] Bradley, W.L., "Toughness Properties of Nodular Iron", *Journal of Metals*, January 1985, pp. 74-76
- [16] Larker, R., "Solution Strengthened Ferritic Ductile Iron ISO 1083/JS/500-10 Provides Superior Consistent Properties in Hydraulic Rotators", Proc. 2008 Keith Millis Symposium on Ductile Cast Iron, Oct. 2008, Las Vegas, Nevada, AFS/DIS, ISBN 978-0-87433-333-6, pp. 169-177. Republished in CHINA FOUNDRY 6 (2009) No. 4, pp. 343-351, Article ID: 1672-6421(2009)04-343-09; downloadable for free at <http://www.foundryworld.com/uploadfile/200912443017589.pdf>
- [17] Björkegren, L. E., and Hamberg, K., "Silicon Alloyed Ductile Iron with Excellent Ductility and Machinability", Proc. 2003 Keith Millis Symposium on Ductile Cast Iron, Hilton Head, SC, Oct. 2003, pp. 70 - 90
- [18] McKinney, K.E., Bradley, W.L., and Gerhardt, P.C., "An Evaluation of the Toughness of Ductile Iron vs. Cast Steel Using Modified Charpy Test Specimens", *AFS Transactions* 84-122, pp. 239-250
- [19] Cabanne, P-M, and Gagné, M., "Wind Energy: A Market for High Quality Ductile Iron Castings", Proc. 66th World Foundry Congress, Istanbul, Turkey, Sept. 2004, Vol. 2, pp. 877-885

- [20] Ratto, P.J.J., Ansaldi, A.F., Fierro, V.E., Agüera, F.R., Alvarez Villar, H.N., and Sikora, J.A., "Low Temperature Impact Tests in Austempered Ductile Iron and Other Spheroidal Graphite Cast Iron Structures", *ISIJ International* 33 (2003), pp. 372-380, ISSN 0915-1559
- [21] Gundlach, R.B., "Nodularity, It's Measurement, and It's Correlation with the Mechanical Properties of Ductile Iron", DIS Research Project No. 37, Ductile Iron Society, Ohio, USA, 2006, 34 pages; downloadable for free at <http://www.ductile.org/member/researchactivity/proj37.pdf>
- [22] Speidel, M. O.: *Z. Werkstofftechn.* 12 (1981) No. 11, p. 387–402
- [23] BAM – GGR 007, Leitlinie zur Verwendung von Gusseisen mit Kugelgraphit für Transport- und Lagerbehälter für radioaktive Stoffe, Rev. 0, BAM Berlin, June 2002
- [24] ISO/TR 15931, *Designation system for cast irons and pig irons*